

कार्यालय अधिष्ठाता  
पं.ज.ने.स्मृति चिकित्सा महाविद्यालय, रायपुर (छ.ग.)  
Phone No. 0771-2890001, 2525602 2523919

क्रमांक.चिकि/कय/2021/ 12262

रायपुर दिनांक .....15/9/21

परिशिष्ट-2

(नियम 4.4.2)

// द्वितीय निविदा आमंत्रण सूचना //

पं.ज.ने.स्मृति चिकित्सा महाविद्यालय रायपुर के खेल मैदान के लिए Movable Back Stop Basketball Unit कय एवं स्थापित किया जाना है। इस कार्य हेतु निर्माताओं तथा उनके अधिकृत विक्रेताओं से मुहरबंद निविदा आमंत्रित की जाती है। निविदा प्रपत्र अधोहस्ताक्षरकर्ता के कार्यालय से आवेदन प्रस्तुत कर रू. 500/- नगद भुगतान कर दिनांक 08.10.2021 के शाम 5.00 बजे तक कार्यालयीन दिवस में प्राप्त किये जा सकते हैं।

निविदा बिक्री की अंतिम तिथि 08.10.2021 समय शाम 5.00 बजे  
निविदा जमा करने की अंतिम तिथि 11.10.2021 समय अपरान्ह 3.00 बजे  
निविदा खोलने की तिथि 11.10.2021 समय शाम 4.00 बजे

जी-62025

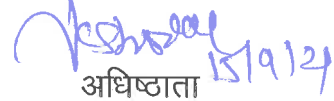
  
अधिष्ठाता 15/9/21  
पं.ज.ने.स्मृति चिकित्सा महाविद्यालय  
रायपुर छ.ग.



### Tender Notice

1	Date of Tender Publishing	17/09/2021
2	Last Date and Time for Submission of Tender	11/10/2021 03:00 PM
3	Opening of Techno commercial Bid	11/10/2021 04:00 PM
4	Address for submission of bid documents	: The Dean, Pt.J.N.M.Medical College, Jail Road, Raipur-492001 (C.G.)
5	Venue for opening of Technical Bid	: Board Room
6	Time of completion of Work	: <b>03 weeks</b> from the date of issue of purchase order
7	EMD	: <b>Rs. 10,000.00 (Rupees ten thousand Only)</b>

**Detailed tender notice can be downloaded from the website of the Pt.J.N.M.Medical College, Raipur**

The right to suspend the tender process or part of the process, to accept or reject any or all the tenders at any stage of the process and/or to modify the process or any part thereof at any time without assigning any reason thereto vests with The, Dean, Pt.J.N.M.Medical College, Raipur without any obligation or liability whatsoever.

*Vishal*

*Sushu*  
14.9.21

*[Signature]*

*[Signature]*

## Check List

S.No.	Name of Documents	Yes/No	Page No.	Remark
1	Tender Fees (Rs. 500/-)			
2	EMD (Security Deposit) Rs. 10,000=00)			
3	GST Registration Certificate			
4	GST Return certificate of last 02 financial year			
5	Audited Annual Turnover certificate (Last Two Financial years)			
6	Satisfactory performance of past supplies.			
7	Copy of Valid PAN Card.			

*Sushu*  
14.01.21.

*Nishu*

*[Signature]*

*[Signature]*

**Procurement of Basketball Poles for Pt.J.N.M.Medical College, Raipur**

1. Pt.J.N.M.Medical College, Raipur invites sealed tenders (under single bid system & limited tender) from Original Equipment Manufacturer (OEM) OR their authorized Dealers for the **Procurement of Movable Back Stop Basket Ball Unit for The College** as per the Technical Specification given in the schedule annexed to the tender.
2. The detailed specifications of the equipment are given in the **Annexure-I** and the same should be compiled with.
3. The bidder should note that the technical specifications mentioned in **Annexure-I** form the core of the product. **The offers must strictly be as per the specifications given in Annexure-I.**
4. The bidder shall ensure that the bid submitted by him includes all equipment, for full execution of requirement. The bidder shall not charge extra for additional items required to meet the operational requirement at the stage of installation.
5. **Quantity requirements of each item as per the specification enclosed at Annexure-I.**

<u>Ser</u>	<u>Particulars of the item(s)</u>	<u>Requirement</u>
1	<b>Procurement of Movable Back Stop Basket Ball Unit for Pt.J.N.M.Medical College, Raipur</b>	Individual item requirements as per Annexure - I

6. The Bidder should be registered with concerned statutory authorities for GST/Income Tax etc. the bidder should furnish relevant GST registration documents and PAN/TAN copies.

  
 14.01.2021





## Procedure for Bid submission

Following is the procedure for submission of Bid, and other important conditions to be fulfilled by the bidder:

7. Every page, containing the said procedure for submission of bid and other important conditions, are to be **signed** by the bidder and to be submitted along with their bids towards their acknowledgement that they have gone through all the contents in these pages and in the Annexure as well and they are agreeing to comply to all of the conditions mentioned there. **NON ADHERENCE TO THIS MAY LEAD TO THE DISQUALIFICATION OF THE BID WITHOUT FURTHER NOTICE.**
8. **ONE BID SYSTEM:** The offers/bids are to be submitted under single bid system. The Bid must contain all the details as specified in the Annexure along with the terms and conditions, also the bid must indicate the quantity & rate clearly as per format at Annexure-II. **THERE MUST NOT BE ANY PRICE ELEMENT IN THE TECHNICAL BID.**
9. **SEALING & MARKING OF BID:** The tender should be submitted in a proper manner with index for easy identification i.e.: -

Envelope Number	To be Super scribed as
A	EMD for Tender & Technical
B	Financial Bid

**Envelope – A (duly sealed):** should contain the Demand Draft / BG towards **Earnest Money Deposit & Technical details of the bid.**

**Envelope – B (duly sealed):** should contain the **Financial Bid.**

All the above two envelopes should clearly be marked on top of envelopes about the type of envelopes (i.e., A, & B, details of contents in envelopes, name of agency submitting the bid.

The envelopes (A, & B ) including the outer bigger envelopes shall be addressed to:

**The Dean**

**Pt.J.N.M.Medical College,**

**Jail Road, Raipur-492001 Chhattisgarh**

The bigger envelopes must be sealed and must bear the following identification on top: -

a) Tender for '**Procurement of Movable Back Stop Basket Ball Unit**

b) Tender Number: 12262 Date: 15/9/2021, and

c) Name and Address of the Bidder. (on bottom left of the envelopes)

If the outer envelope is not sealed and not marked as above, the College will assume no responsibility for the misplacement or premature opening of Bid.

10. **SUBMISSION OF TENDER:** The tender can be personally submitted on all working days (except 2<sup>nd</sup> & 3<sup>rd</sup> Saturday, Sunday & Holidays) between 11.00am and 4.00pm before the date and time as specified in the Tender Notice and up to **3:00pm** on the last date of submission of tender. The tender can also be sent by registered post to **The Dean, Pt.J.N.M.Medical College, Jail Road, Raipur-492001, Chhattisgarh.** Tender shall not be received after expiry of the time as specified on the 1<sup>st</sup> page of the tender notice.

**TECHNO- COMMERCIAL BID**

11. The bidder must submit the following documents/information with the Bid.:

- a. The entire tender document duly signed on each page.
- b. Copy of the valid PAN Card, Goods & Sales Tax Registration be forwarded.
- c. EMD has sought in the succeeding paragraphs of this document. In case seek EMD exemption under SMEs, Certificate from MSME explicitly mentioning as a supplier of **Movable Back Stop Basket Ball Unit** shall be forwarded in addition.
- d. The offer/bid will be opened by a Committee, as would be constituted by the competent authority, at a pre-defined place, time and date in the presence of all such bidders and/or their authorized representatives. The Financial Bid should be submitted as per the format enclosed with the tender document on the letter Head of the Firm/Agency. The rate should be clearly submitted with breakup of Basic Price, GST, Custom Duty etc. **Financial Bid in any other form will not be accepted and be SUMMARILY REJECTED.**
- e. Bidder should submit proof of Turnover certified by CA for the last 2 financial year. Bidder have an average minimum Rs. 20 Lakh annually.
- f. Bidder should submit Satisfactory performance Certificate of past supplies.

**Criteria for Qualification in the Technical Bid**

The above mentioned basic eligibility conditions and additional clauses are broad guidelines for pre-qualification and the Dean, Pt.J.N.M.Medical College, Raipur hereby reserves the right to relax/alter/modify/add any or all the conditions.

**12. EARNEST MONEY DEPOSIT (EMD):**

**Rs. 10,000.00 (Rupees Ten Thousand Only)** in the form of a **Demand Draft or Bank Guarantee** drawn in favor of "The Dean Pt.J.N.M.Medical College, Raipur" and payable at any nationalized or scheduled bank with a branch at Raipur. Photocopy/Fax copy of the demand draft / BG will not be accepted.

- Bidders registered with NSIC / MSME and those who have already submitted are exempted from EMD, provided the certificate from the body clearly mentions the equipment/item/store/service/es which is / are being procured.
- However, EMD shall be paid in cases where the registered vendor seeks payment in currencies other than INR and / or a non OEM supplier represents a foreign firm. Any tender without original EMD (other than where exempted) would be considered "DISQUALIFIED" and hence would be **REJECTED**.

**13. RETURN OF EMD:**

- The EMD of the unsuccessful bidders will be returned to them without any interest on receipt of written request from them within thirty days after awarding the contract to the successful bidders.
- The EMD of the successful Bidder will be returned after receiving Performance Bank Guarantee covering the contract & the warranty period.

**14. FORFEITURE OF EMD:**

After receiving the Purchase Order, if the OEM/Bidder is unable to execute the order satisfactorily, the Earnest Money Deposit will be forfeited and the College will be constrained to take necessary action against the OEM/Bidder.

**15. WARRANTY BANK GUARANTEE (WBG) FOR SUCCESSFUL BIDDER**

- The successful bidder(s) should provide a performance bank guarantee amounting 10% of the order value in the format provided by The College within 15 days of receiving the order. The WBG should be valid for the period of contract covering the entire warranty period of five years plus two months.
- If the successful bidder(s) is/are unable to provide WBG within the stipulated period, his/their EMD will be forfeited by Pt.J.N.M.Medical College, Raipur with or without consulting.

**16. BID VALIDITY:**

- The Bid shall remain valid for the period not less than three (3) months after the last date set for bid submission.
- A bid submitted for a bid validity of shorter period may be rejected as non-responsive.

**17. LATE BID:**

Any bid received after the dead line as prescribed in the tender notice will be treated as a late bid and will not be considered.

**18. ACCEPTANCE AND REJECTION:**

The right to shortlist/reject any or all the tenders and/or to accept the whole or any part of the tenders without assigning any reason whatsoever would vest with the Purchase Committee of the College,

**19. DELIVERY PERIOD:**

**03 Weeks** from the date of placement of Purchase Order. On completion of the manufacturing of the item ordered for, the OEM/Bidders will have to inform the same to the Dean, Pt.J.N.M.Medical College, Jail Road, Raipur, Chhattisgarh, India, who will instruct the OEM/Bidder about the location for delivery of the materials and date of delivery.

**20. DELIVERY TERMS:**

Items should be delivered on F.O.R. door delivery basis at Pt.J.N.M.Medical College, Raipur – 492001, Chhattisgarh within the quoted price. The supplier should arrange for entire process from unloading to commissioning and demonstration within the quoted price.

**21. FREIGHT & INSURANCE:**

No freight and insurance charges will be provided and the materials are to be delivered at Pt.J.N.M.Medical College, Raipur Campus, as may be desired by the College at the cost and risk of the OEM/Bidder within quoted price.

**22. WARRANTY DECLARATION:**

- The Bidder/OEM must give a comprehensive support and maintenance for a period of ONE year from the date of commissioning and acceptance of the material.
- Any deviation in the equipment, and the specification from the accepted terms and conditions may be liable to be rejected and the bidder/manufacturer needs to supply all the items in the specified form to the satisfaction/ specifications specified in the order and demonstrate at their own cost. The payments shall be made only after receiving the materials as per required specification and quality to the satisfaction of the competent authority of Pt.J.N.M.Medical College, Raipur.

*Neshu*

*Sudh*

*14.9.21*

*[Signature]*

*[Signature]*



**23. FAILURE OF ORDER EXECUTION:**

If a successful bidder after receiving the order fails to execute the order within the stipulated period or does not fulfill any of the terms and conditions in any respect, The Dean, Pt.J.N.M.Medical College, Raipur reserves the right to cancel the order unilaterally and forfeit the PBG amount.

**24. INSTALLATION & DEMONSTRATION:**

- The supplier is required to carry out the installation and demonstration of the equipment at the Pt.J.N.M.Medical College, Raipur installation site within the delivery period; otherwise the penalty clause will be the same as per the supply of material (refer to the liquidated damages below).
- In case of any mishandling/damage to equipment and supplies during carriage from the origin of equipment to the installation site, the supplier has to replace it with new equipment/supplies immediately at his own risk of cost. Supplier will settle his claim with the insurance company as per his convenience. Pt.J.N.M.Medical College, Raipur will not be liable for any type of losses in any form.

**25. PAYMENT TERM:**

90 % Payment shall be made after the successful delivery, installation, commissioning, demonstration and acceptance of the equipment at Pt.J.N.M.Medical College, Raipur and 10% after the submission of WBG. WBG should be of any Nationalized / scheduled bank with a branch at Raipur, Chhattisgarh. No request for change in terms of payment will be accepted. Nil advance will be paid.

**26. LIQUIDATED DAMAGES:**

The equipment should be delivered/dispatched to destination and ready for use not later than the delivery period specified. If the OEM/Bidder fails to deliver any or all the stores or perform the service by the specified date, liquidated damages @2% per month or part thereof in respect of the value of the delayed stores will be deducted from the bill subject to a maximum of 10%. Same terms are applicable for installation, training and demonstration clause mentioned above.

**27. FINAL SELECTION AND AWARD CRITERIA:**

L-1 Criteria. The L<sub>1</sub> will be decided on the base price of **Procurement of Movable Back Stop Basket Ball Unit as per Annexure-I**, the lowest bidder will be adjudged L<sub>1</sub>. All levies/taxes (i.e. Custom Duty, GST etc.) must be clearly mentioned separately (as per format of commercial bid) However, the decision of the Competent authority will be final and binding in awarding the order. In case of any clarification required, the same can be clarified from Pt.J.N.M.Medical College, Raipur before submission of the bids.

**28. DISPUTE AND JURISDICTION:**

Any legal disputes arising out of any breach of contract pertaining to the whole process of this tender shall be settled in the court of competent jurisdiction in the district of Raipur, Chhattisgarh.

**29. ACKNOWLEDGEMENT BY THE BIDDER:**

It is hereby acknowledged that we have gone through all the schedules as well as the conditions mentioned above and we agree to abide by these.

Date:

Signature of the Bidder along  
with official seal.

Place:

CANVASSING OR OFFERING AN ADVANTAGE OR ANY OTHER INDUCEMENT BY ANY PERSON WITH A VIEW TO INFLUENCING ACCEPTANCE OF A BID WILL BE AN OFFENSE UNDER LAWS OF INDIA. SUCH ACTION WILL RESULT IN THE REJECTION OF BID, IN ADDITION TO OTHER PUNITIVE MEASURES.

Encl:

- Technical Specifications at Annexure I
- Information with technical bid at Annexure II
- Format of Commercial Bid at Annexure-III
- Format of declaration (Not Blacklisted) at Annexure IV
- Format of Bank Guarantee at annexure V

The Dean  
Pt.J.N.M.Medical College, Raipur



### 1 Backstop unit

There shall be 2 backstop units, 1 placed at each end of the playing court and each consisting of the following parts:

- 1 backboard.
- 1 basket ring with a ring mounting plate.
- 1 basket net.
- 1 backboard support structure.
- Padding.

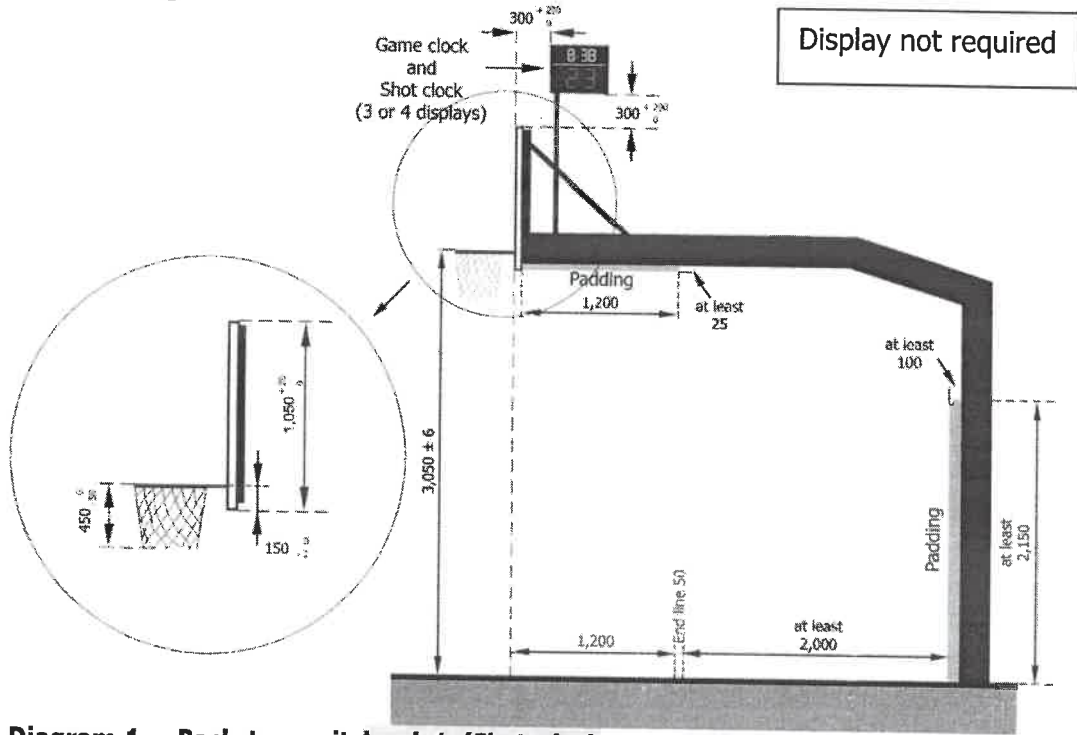

Diagram 1 Backstop unit level 1 (Shot clock option 1)

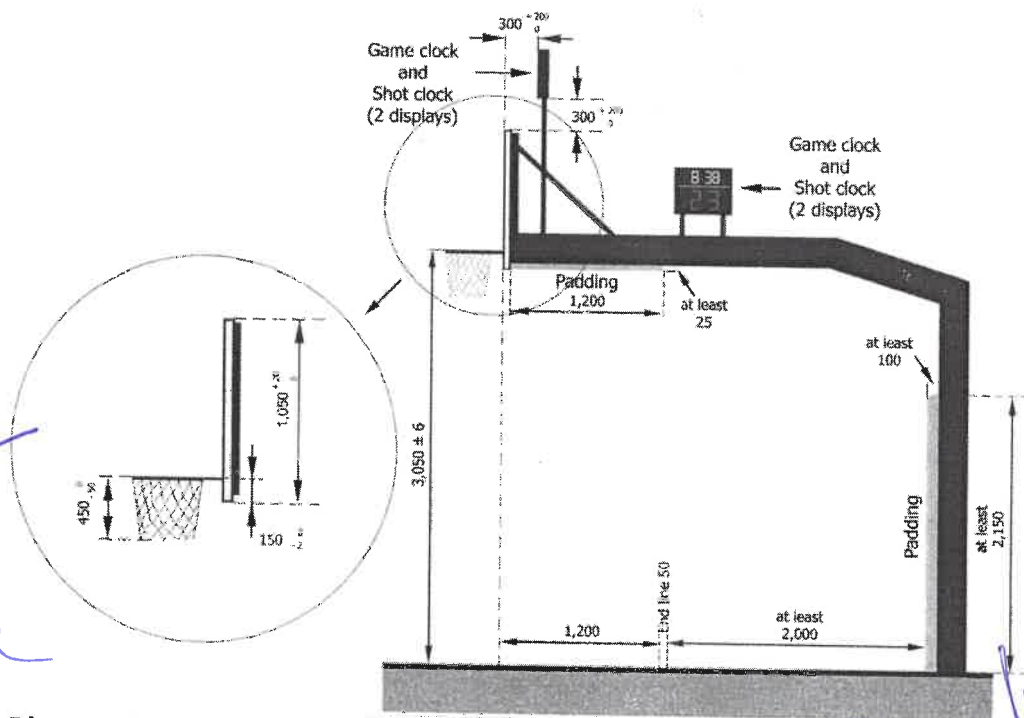

Diagram 2 Backstop unit level 1 (Shot clock option 2)

*03/09/21*  
*Yes*

*[Handwritten signature]*

### 1.1 Backboard

- 1.1.1. For Level 1 the backboards shall be made of non-reflective laminated safety glass or tempered glass, with a thickness of between 11.8 mm and 13.5 mm, with a flat front surface and shall:
  - Have a protective framework of the backboard support structure around the outer edge.
  - Be manufactured such that, if broken, the pieces of glass do not split off or cause any risk of injury.
- 1.1.2. The backboards shall measure 1,800 mm (+ a maximum of 30 mm) horizontally and 1,050 mm (+ a maximum of 20 mm) vertically, including the frame.
- 1.1.3. All lines on the backboards shall be:
  - In white, if the backboards are transparent.
  - In black, if the backboards are painted white (Level 2 only).
  - 50 mm in width.
- 1.1.4. The borders of the backboards shall be marked with a boundary line (Diagram 3) and an additional rectangle behind the ring as follows:
  - Outside dimensions: 590 mm (+ a maximum of 20 mm) horizontally and 450 mm (+ a maximum of 8 mm) vertically.
  - The top edge of the base of the rectangle shall be level with the top of the ring and 150 mm (- 2 mm) above the bottom edge of the backboard.
- 1.1.5. For Level 1, each backboard shall be equipped with a light strip around its perimeter, mounted on the inside borders of the backboards and which lights up in red only when the game clock signal sounds for the end of a quarter or overtime. The light strip shall be a minimum of 10 mm in width and cover a minimum of 90 % along the edge of the backboard glass area.
- 1.1.6. For Level 1, when a basketball is dropped onto the backboard, from 1.8 m, it shall rebound from it with a minimum rebounding height of 50 %.

03/09/21 ...

Suslan  
14-9-21

Yes here

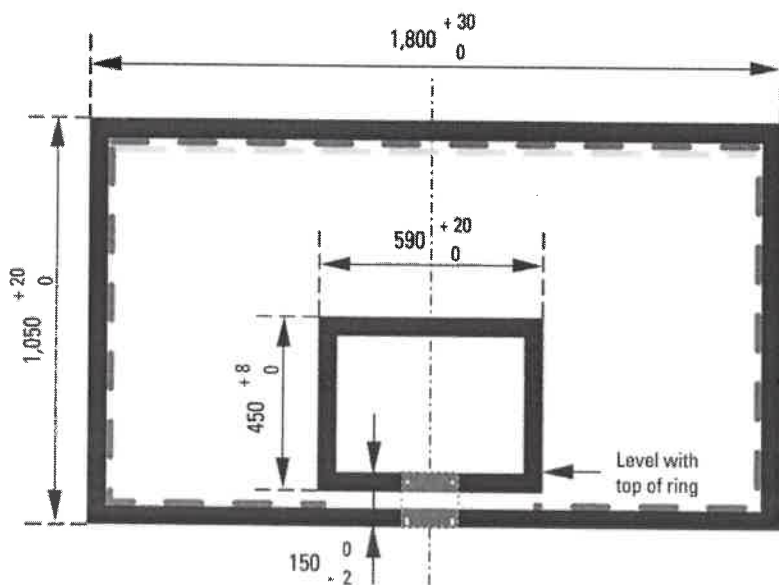

Diagram 3 Backboard markings

### 1.2 Basket ring

1.2.1 The rings shall be made of solid steel and shall:

- Have an inside diameter of a minimum of 450 mm and a maximum of 459 mm.
- Be painted orange within the following Natural Colour System (NCS) or RAL CLASSIC spectrums:

NCS:	RAL:
S0580-Y70R (CMYK: 0, 63, 79, 4)	RAL 2004 (CMYK: 0, 65, 87, 0)
S0585-Y70R (CMYK: 0, 70, 92, 5)	RAL 2008 (CMYK: 0, 70, 90, 0)
S1080-Y70R (CMYK: 0, 65, 85, 13)	RAL 2010 (CMYK: 0, 78, 100, 0)

- Have its metal a minimum of 16 mm and a maximum of 20 mm in diameter.

1.2.2 The net shall be attached to each ring in 12 places. The fittings for the attachment shall:

- Not have any sharp edges or gaps,
- Have gaps smaller than 8 mm, to prevent fingers from entering,
- Not be designed as hooks for Level 1.

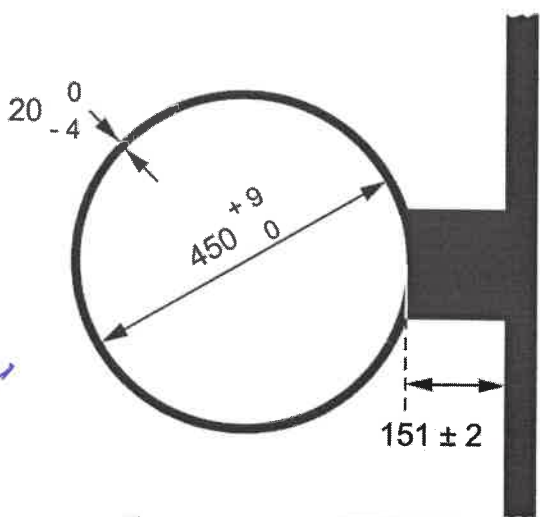

Diagram 4 Basket ring dimensions

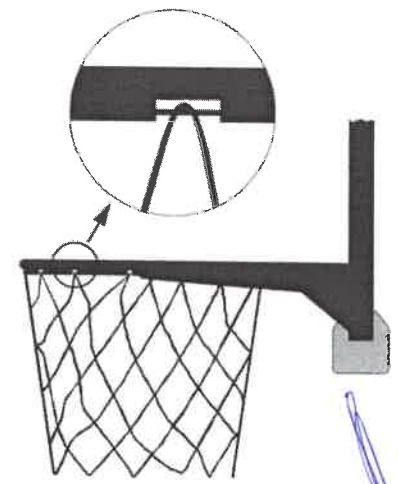

Diagram 5 Attachment of the net (example)

*Handwritten signature and date: 03/09/21*

*Handwritten signature*

*Handwritten signature and date: 14.9.21*

*Handwritten signature*

*Handwritten signature*

- 1.2.3 The rings shall be fixed to the backboard support structures in such a way that any force applied to the ring cannot be transferred to the backboard itself. Therefore, there shall be no direct contact between the ring mounting plate and the backboard (Diagram 6).
- 1.2.4 The top edge of each ring shall be positioned horizontally, 3,050 mm ( $\pm$  a maximum of 6 mm) above the floor, equidistant from the 2 vertical edges of the backboard.
- 1.2.5 The point on the inside circumference of the ring nearest the backboard shall be 151 mm ( $\pm$  a maximum of 2 mm) from the face of the backboard.

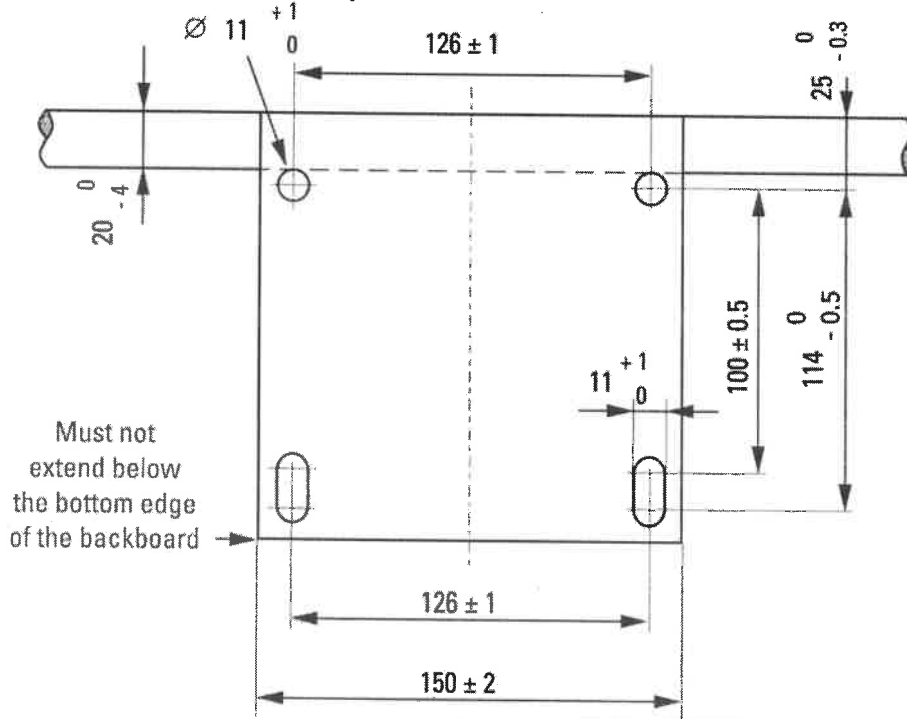

**Diagram 6 Ring mounting plate (example dimensions)**

- 1.2.6 For existing basket support structures, it is recommended that the ring mounting plate be fixed to the framework according to the measurements given in Diagram 7.

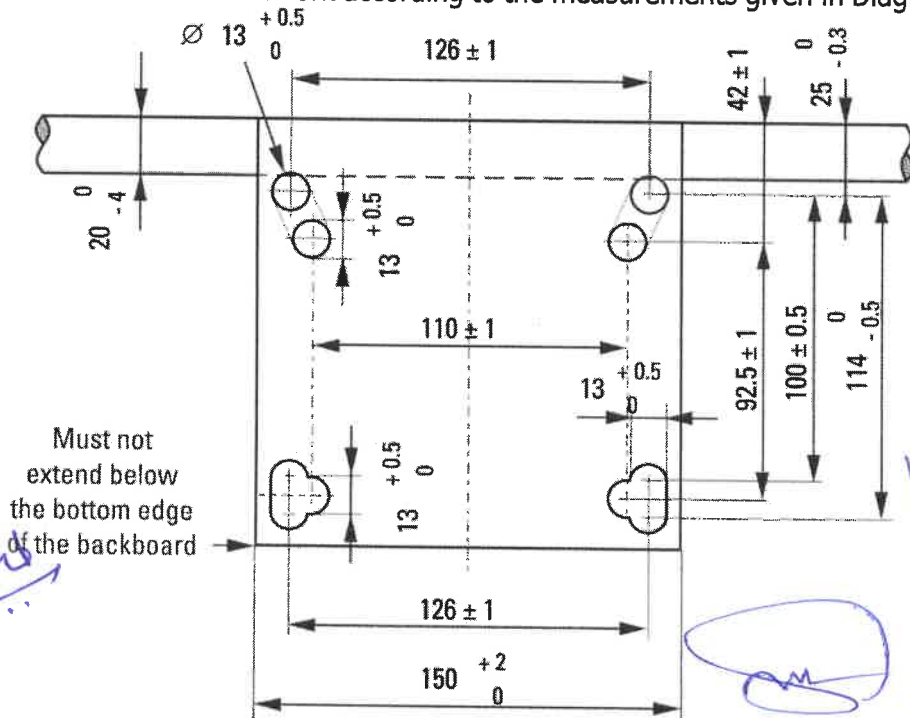

**Diagram 7 Ring mounting plate for existing baskets (example dimensions)**

*Handwritten notes:*  
03/09/21...  
Vskul

*Handwritten signature and date:*  
S...  
14.9.21

1.2.7 Pressure release rings with the following specifications are required for Level 1 and also for Level 2 products requesting FIBA approval:

- The pressure release mechanism shall not cause any damage to either the ring or the backboard. The design of the ring and its construction shall be such that the players' safety is ensured.
- The pressure release rings shall have a 'positive-lock' mechanism which must not disengage until a static load of a minimum of 82 kg and a maximum of 105 kg has been applied vertically to the top of the ring at the most distant point from the backboard. The pressure release ring mechanism shall be adjustable within the given static load range.
- When the pressure release mechanism is released, the front or the side of the ring shall rotate no more than 30 degrees and no less than 10 degrees below the original horizontal position.
- After release and with the load no longer applied the ring shall return automatically and instantly to its original position. No fissures and no permanent deformation of the ring shall be observed.
- The rebound/elasticity of the ring and support system shall be within 35 % - 50 % energy absorption range of the total impact energy. Two opposing rings shall fall within 5% units of one another.

### 1.3 Basket net

1.3.1 The nets shall be made of white cord and shall be:

- Suspended from the rings.
- Manufactured so that they check the ball momentarily as it passes through the basket.
- No less than 400 mm and no more than 450 mm in length.
- Manufactured with 12 loops to attach it to the ring.

1.3.2 The upper section of the net shall be semi-rigid to prevent:

- The net from rebounding up through or over the ring, creating possible entanglement.
- The ball from becoming trapped in the net or rebounding back out of the net.

### 1.4 Backboard support structure

1.4.1 For Level 1, only mobile or floor-fixed backboard support structures shall be used. For Level 2, in addition to mobile or floor-fixed, ceiling mounted or wall mounted backboard support structures may also be used. Ceiling mounted backboards shall not be used in venues where suspension height exceeds 10,000 mm in order to avoid excessive vibration in the support structure.

1.4.2 The backboard support structure shall be:

- For Level 1, at a distance of at least 2,000 mm, measured from the outer edge of the endline to the front of the backstop padding (Diagram 1 or 2).
- For Level 2, at a distance of at least 1,000 mm, measured from the outer edge of the endline to the front of the backstop padding. For wall or ceiling mounted units this measurement shall be taken from the outer edge of the endline to the wall or nearest obstacle.
- Of a colour, that sufficiently contrasts with the background, so that it is clearly visible to the players.

23/09/21

Not used

14.9.21

- Secured to the playing floor so as to prevent any movement. If playing floor anchoring is not possible, sufficient ballast weight on the basket support base must be used to prevent any movement.
- Adjusted such as that once the top edge of the ring is at a height of 3,050 mm from the playing floor, this height cannot be changed.
- The rigidity of the backboard support structure with ring shall fulfil the requirements of EN 1270.
- The vibration of the backboard support unit in which the displacement exceeds 5 mm, shall last less than 4 seconds after a dunk shot.

## 1.5 Padding

- 1.5.1 The backboard and backboard support structure must be padded.
- 1.5.2 The padding shall be of a single solid colour and shall be the same colour on both backboards and support structures.
- 1.5.3 The backboard padding shall be 20 to 27 mm thick from the front, back and side surface of the backboards. The padding shall be 48 to 55 mm thick from the bottom edge of the backboards.
- 1.5.4 The backboard padding shall cover the bottom surface of each backboard and the side surface to a distance of 350 to 450 mm from the bottom. The front and back surface must be covered to a minimum distance of 20 to 25 mm from the bottom of each backboard.

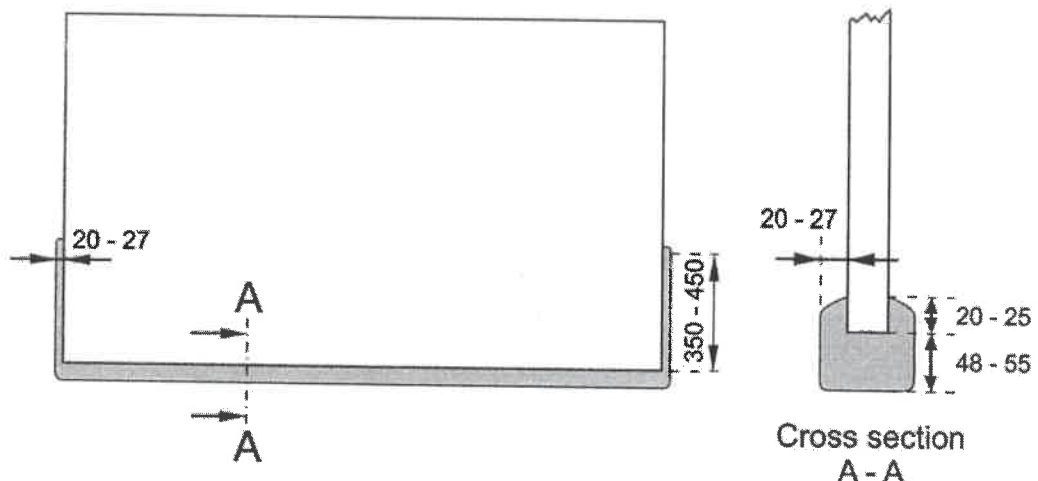

**Diagram 8 Backboard padding**

- 1.5.5 The padding of the backboard support structure shall cover:
- The vertical edges on each side, to a minimum height of 2,150 mm from the playing floor and with a minimum thickness of 100 mm (Diagram 1 or 2).
  - The bottom and side surfaces of the supporting arm of the backboard, from the back surface of the backboard over a minimum length of 1,200 mm along the arm, with a minimum thickness of 25 mm (Diagram 1 or 2).
- 1.5.6 To protect players during impact all padding shall:
- Be constructed so as to prevent limbs from being trapped.
  - Have a maximum indentation factor of 50 %. This means that when a force is applied suddenly to the padding, the indentation in the padding does not exceed 50 % of its original thickness.
  - Have a peak deceleration value of 500 m/s<sup>2</sup> or less.

1.5.6

To protect players during impact all padding shall:

- Be constructed so as to prevent limbs from being trapped.
- Have a maximum indentation factor of 50 %. This means that when a force is applied suddenly to the padding, the indentation in the padding does not exceed 50 % of its original thickness.
- Have a peak deceleration value of 500 m/s<sup>2</sup> or less.

## 2 Basketballs

2.1 For Level 1, the outer surface of the ball shall be made of leather or artificial/composite/synthetic leather.

For Level 2, in addition to leather and artificial/composite/ synthetic leather, the outer surface of the ball may be made of rubber.

2.2 The surface of the ball shall comply fully with the relevant local and national legislation including adherence to any applicable safety directives regarding the use of toxic materials and materials which may cause an allergic reaction, including AZO-dyes, soluble heavy metals, Phthalate and PAH. It is the responsibility of the ball manufacturer to test their balls according to applicable legislation.

2.3 The basketball surface shall provide a proper grip over the entire ball.

2.4 The ball shall:

- Be spherical, with a maximum of 12 seams not exceeding 6.35 mm in width and, either of a single shade of orange or of a FIBA approved colour combination.
- Be inflated to an air pressure such that, when it is dropped onto the playing floor from a height of approximately 1,800 mm measured from the underside of the ball, it shall rebound to a height of between 960 mm and 1,160 mm, measured to the underside of the ball.
- Be marked with the recommended inflation pressure or pressure range.
- Be marked with its respective size number.
- Be within the circumference and weight tolerances outlined in Table 1. For all men’s competitions a size 7 ball shall be used; for all women’s competitions a size 6 ball shall be used; for all mini’s basketball a size 5 or size lightweight 5 ball shall be used.

Ball Size	7	6	5	Lightweight 5
Circumference	750 - 770 mm	715 - 730 mm	685 - 700 mm	685 - 700 mm
Weight	580 - 620 g	510 - 550 g	465 - 495 g	360 - 390 g

Table 1 Basketball circumference and weight tolerances

2.5 In addition to checking the specifications listed above, the ball shall meet the requirements of the following:

- Durability test
- Loss of pressure test
- Inflation stress test (Level 1 only)
- Heat storage test (Level 1 only)

## 3 Scoreboard/Videoboard

3.1 For Level 1, two large scoreboards or videoboards shall be:

- Placed one at each end of the playing court,
  - If there is a scoreboard (cube) placed above the centre of the playing court, one duplicate scoreboard on the opposite side of the players' benches, clearly visible to both teams, will be sufficient,
  - Clearly visible to everyone involved in the game, including the spectators.
- If video displays are used the complete required game information must be visible at any time during the game including intervals of play. The readability of the displayed information shall be identical compared to that of a digital scoreboard.

*Handwritten signature and date: 03/09/21*

*Handwritten signature*

*Handwritten signature and date: 14-9-21*

*Handwritten signature*

*Handwritten signature*



## ANNEXURE-II

TO BE TYPED ON THE LETTER HEAD OF THE BIDDER/MANUFACTURER

To,  
 The Dean  
 Pt.J.N.M.Medical College  
 Jail Road, Raipur (C.G.)

Subject : Supply & Installation of Movable Back Stop Basket Ball Unit

Sir, Ref.: Tender Notice No. \_\_\_\_\_, Date \_\_\_\_\_.  
 I/We do hereby submit our Commercial Bid for the Supply & Installation of Movable Back Stop Basket Ball Unit against the tender notice under reference.

[Mention all figures in Indian Rupees, Include all charges]

PRICE SCHEDULE					
S. No.	Category	Units	Base Price (in ₹)	Taxes	Total Price (with Currency)
1	Movable Back Stop Basket Ball Unit Including Transports and Installation Charges	1 PAIR			
4	Grand Total				

## Note:

All required services need to be set up, as per the specifications, in a satisfactory manner, for a successful commissioning. In case of any mistake or error in calculations or any discrepancy in price quoted in word and figures, the LOWEST amount will be considered for comparison. If this lowest price is not acceptable to the bidder, their bid will be rejected. In this case, The Dean, Pt.J.N.M.Medical College, Raipur reserves the right to forfeit their EMD. L<sub>1</sub> is calculated based on the base price without GST.

**Declaration:** I/We do hereby accept all the terms and conditions laid down in the tender notice for the above said supply. I/We also agree to the condition that the right to suspend the tender process or part of the process, to accept or reject any or all the tenders at any stage of the process and/or to modify the process or any part thereof at any time without assigning any reasons thereto is reserved by the Competent authority of the College without any obligation or liability whatsoever.

Signature of the Bidder/Manufacturer with date and seal

  
14-9-21





